



### FEATURES

- Designed to meet or exceed IP66
- Choice of colors, markings, and illumination
- Crisp detent action

### MOUNTING

MATERIAL	X	Y
.75 - 1.25	36.6+0.2	21.2-0.0
1.25 - 2.0	36.8+0.2	21.2-0.0
2.0 - 3.0	37.0+0.2	21.2-0.0

**NOTE: CUTOUT SIZE for REFERENCE ONLY!**  
Size can vary depending on thickness of material used.

No hardware or tools needed, self locks into proper panel cutout .835" (21.2 mm) x 1.441 to 1.457" (36.6 to 37.0 mm).

Acceptable panel thickness range is from .030" (.75 mm) to .118" (3.00 mm).



**CAUTION!** Burr direction must be away from the direction of insertion.

### TERMINATION

Standard is solderless .250" (6.35 mm) wide x .032" (.81 mm) thick.

Solder terminals are also available.

### AMPS VOLTAGE

20A	125 VAC
10A	250 VAC
12A	125V 3/4 H.P.
10A	277V 3/4 H.P.
21A	14V DC

### APPROVALS

UL, CUL, RoHS compliant, IP66

### PART NUMBER DESIGNATION

<b>260</b>	<b>H</b>	-						
Series	1	2	3	3	4	4	4	5
Circuit	Button	Frame	Button	Lens 1	Lens 2	Lens 2	Light	
	Type	Color	Color	Color	Color	Color	Voltage	

Example: 260H-4BRWN12

A 260 Series DPST on/off switch with button type #4 (one illuminated window). The frame color will be black with a red button. The first lens color will be white and there is no second, so the color is none. The lighting voltage for this switch would be 12VDC.

### 1. CIRCUIT CODES

B = SPST on/off
C = SPDT on/on
D = SPDT on/off/on
E = DPDT on/on
F = SPDT mom-on/off/mom-on
G = SPST mom-on/off
H = DPST on/off
I = DPST mom-on/off
J = DPDT mom-on/on
K = DPST on/mom-off
L = SPST on/mom-off
N = SPDT mom-on/off/on
P = DPDT on/off/on
Q = SPDT mom-on/on
R = DPDT on/off/mom-on
S = DPDT mom-on/off/mom-on

### 2. BUTTON TYPES

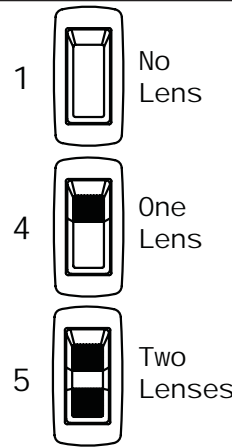

### 3. FRAME/BUTTON COLORS

B = Black
W = White
R = Red

### 4. LENS COLORS

A = Amber	R = Red
G = Green	W = White
U = Blue	N = None

### 5. LIGHT VOLTAGE

12 = 12VDC
28 = 28VDC
125 = 125VAC
250 = 250VAC
N = Non-Illuminated

### 260 SERIES (260H-1BBNNN Shown for reference purposes)

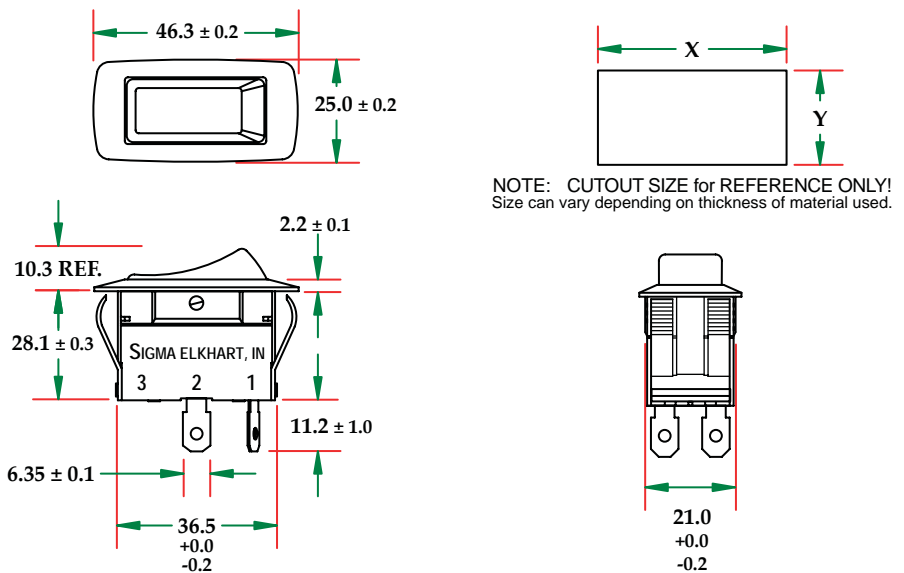

**SIGMA**  
SWITCHES PLUS  
4703 Wyland Dr.  
Elkhart, IN 46516  
Tel: 574-294-5776  
Fax: 574-294-8744

www.sigmaswitches.com

### OUR COMMITMENT TO YOU

We are constantly adding to and improving our selection of Rocker, Toggle, Push Button and other types of switches. If you don't find it here, or on the pages of our website, feel free to contact us for the most current information. If you need a specially designed custom switch, we can discuss your custom design requirements as well. We look forward to helping you with your next switch purchase.